



Prof.Dr. Omer Soykasap

Afyon Kocatepe University,

Department of Material Science and Engineering

Afyonkarahisar, TURKEY

E-mail: soykasap@aku.edu.tr

Web: www2.aku.edu.tr/~soykasap

- **Dr. Omer Soykasap** has BSc in Aeronautical Engineering from Istanbul Technical University, MSc and Ph.D. in Aerospace Engineering from Georgia Institute of Technology,. He is currently Prof. of Material Science and Engineering of AKU.
- He worked as Research Associate and Senior Research Associate at Deployable Structures Lab, University of Cambridge for 3.5 years.
- He has conducted funded researches on deployable space structures such as deployable antenna structures, reflectors, solar panels, composite hinges, and on design and structural analysis of aerospace structures, which are funded by national and international bodies including EADS Astrium, QinetiQ Ltd, ESA, The Cambridge-MIT Institute, and TUBITAK.
- He has made significant contributions on aerospace and deployable space structures and is given several awards to his research.

Afyon Kocatepe University

- 15 faculties, 40000 students, 766 academic staff and 308 researchers
- **Department of Mechanical Engineering/Material Science** is renowned for its high quality postgraduate teaching and research, and for its links to industry and business.
- It has a long record in the successful and execution of research in all aspect of **advanced design and manufacturing, covering finite element analysis, complex product design and composite materials.**
- It has a number laboratories including **mechanical vibrations, composite materials, vehicle dynamics, CAD/CAM and mechatronics**, which will provide to effectively carry out the proposed research project.
- It has many international links to universities in Europe.
- We study **modeling , development, analysis and testing of composite structures/materials** for space and aerospace applications funded by national and international institutions.

New Faculty: Faculty of Aeronautics and Astronautics

- In order to carry out training and research activities under an institutional framework, the opening of Faculty of Aeronautics and Astronautics was approved by the Higher Education Council, The Ministry of Education, and The Board of Ministers of the Turkey in August 2014.
- After completion of its infrastructure, the undergraduate and graduate programs at the faculty will be established soon and the education will begin in coming years.
- Dr. Soykasap is the key personnel at the university with a PhD. in aerospace engineering, and worked on several space projects funded by national and international institutions. He will be teaching staff, possibly become the head of department and/or dean of the faculty with strong background in space education and research.

Research Activities

Deployable Solar Array, Hinges, booms, 2003-2008

Metallic or Composite Hinges

Deployable Solar Array

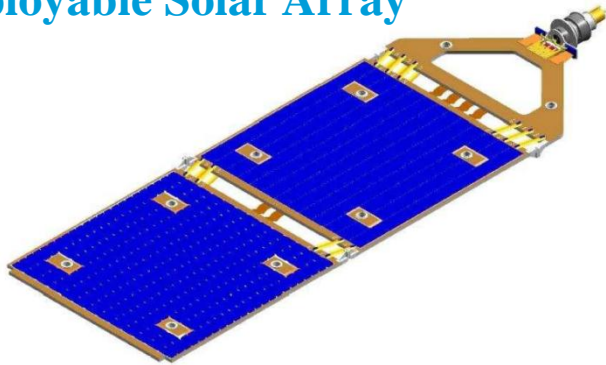

Simulation and testing of solar array

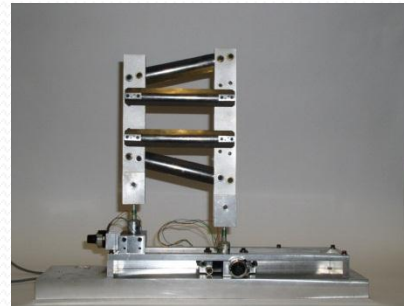

Development and testing of solar panel hinges

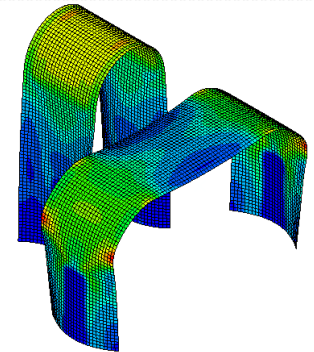
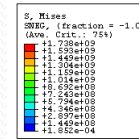

Composite booms

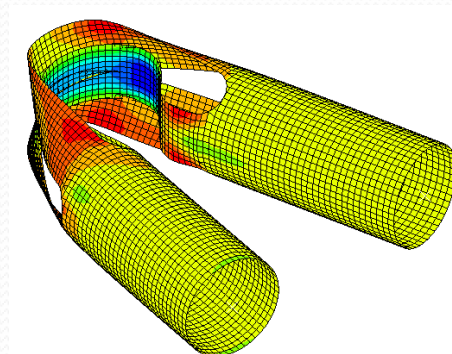
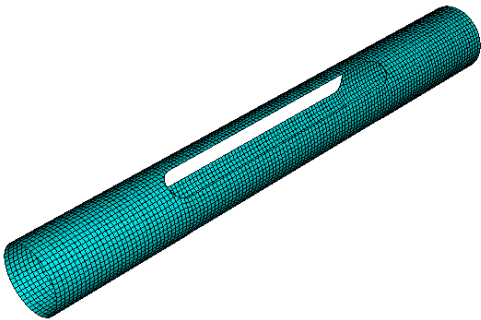

Development and testing of booms

Research Activities

Antennas, Deployable Composite Shell Reflectors, 2003-2008

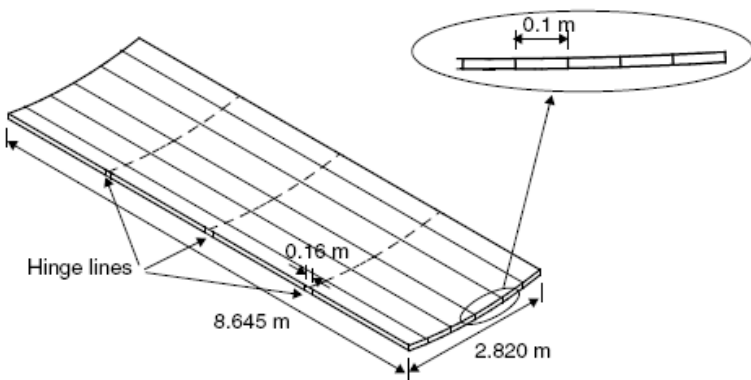
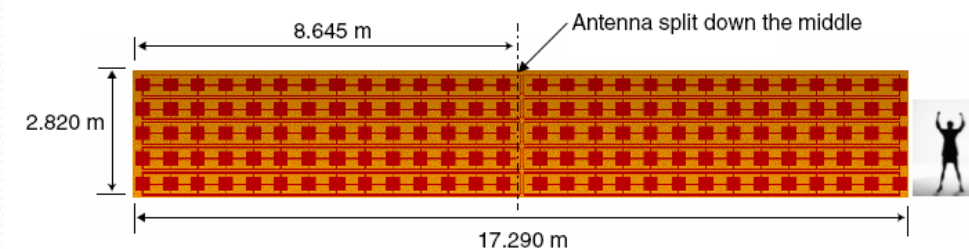
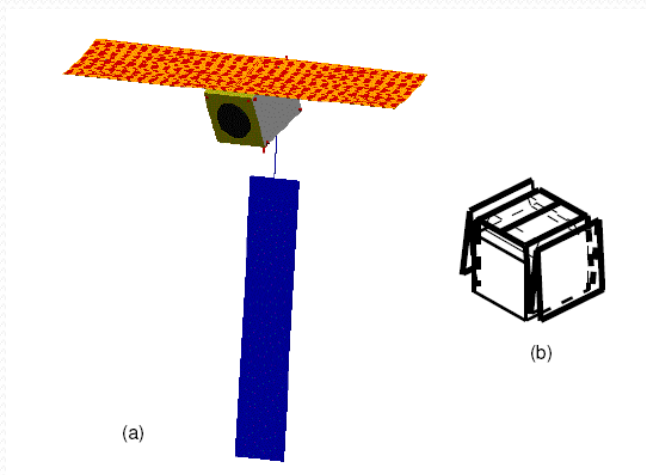

P-band antenna, University of Cambridge,
 50m^2 , 1.4 kg/m^2 , 2004

Research Activities

Deployable Composite SAR Reflector, 7.9mx3.2m, 2002-2004

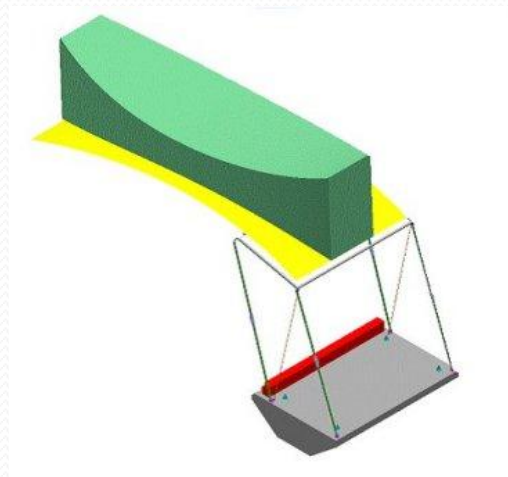
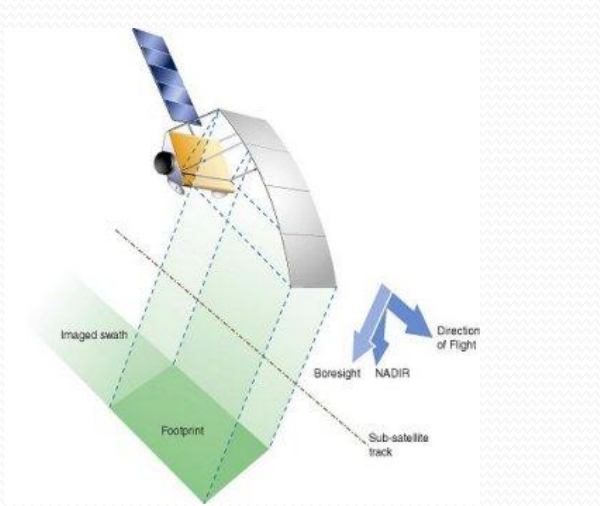

SAR reflector, University of Cambridge, 2003, mass= 33 kg (2.5 times lighter than previous technology) 1.3 kg/m²

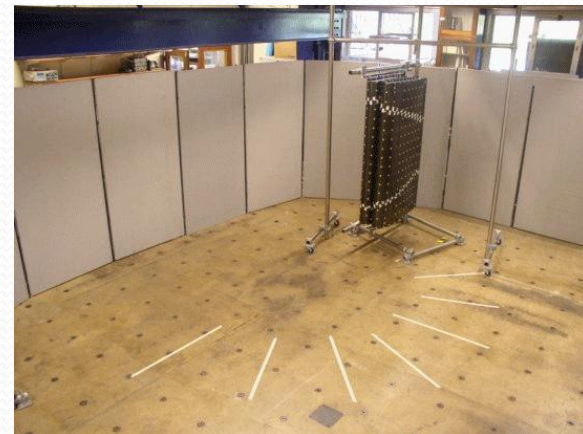
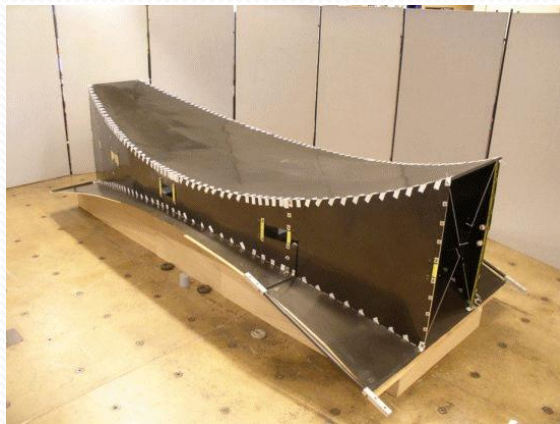

Research Activities

Deployable Composite Shell Reflectors (2004-2015)

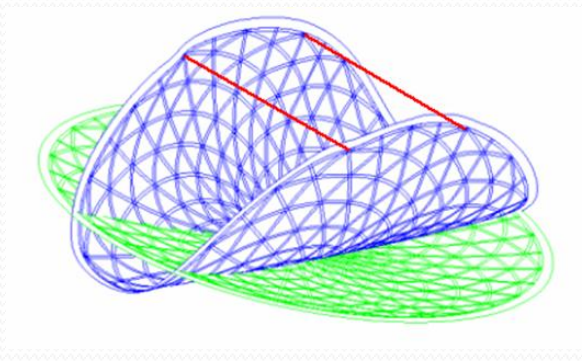

Stiffened Spring back reflector, TAHARA project, University of Cambridge, British Council, 2004-2009

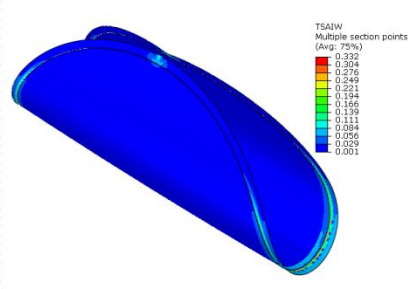

2009-present,

- We design and analysis new foldable and space deployable reflector antenna for Ku-band telecommunication, X-band earth observation
- 3-6m diameter, made of carbon/epoxy, ultra thin shell, self deployable, low mass and low cost

Research Activities

Composite Structures and Materials

FP7 project, Smart Intelligent Aircraft Structures (SARISTU) 2011-2015

- One of the most prestigious FP7 projects. The main beneficiary is [Airbus](#). There are 65 partners and it has a budget of 50.95 million euro.
- At AKU, we study modeling and simulation studies of composite materials with [carbon nano tube](#) for lightning damage.



Thermo-mechanical Behavior of Woven Composites

- Behavior by FE model and analytical approaches
- Elastic, thermal and electrical properties, strength, CTE, natural frequency, vibration damping, fatigue, and ballistic properties

